



www.naftec.org

email: mail@naftec.org

National Food Technology Research Centre

Endless possibilities in food research

Improvements in Sorghum Milling Technologies

Martin M Kebakile (PhD)

martin@naftec.org

Introduction



- /// Sorghum is staple food for millions in African and Asian countries
- /// It ranks 5th in production worldwide, but is 2nd most important after maize in Africa
- /// The crop is adapted to drought conditions and therefore could be a strategic grain for food security in Sub-Saharan Africa

Limitations

- /// Sorghum has been neglected until recently; Little R&D efforts compared to other common cereals
- /// Sorghum food industry is non-vibrant (largely traditional products)
- /// Generally there is lack of suitable sorghum food processing technologies
- /// Low production capacity
- /// High milling losses
- /// Variable product quality



Sorghum milling

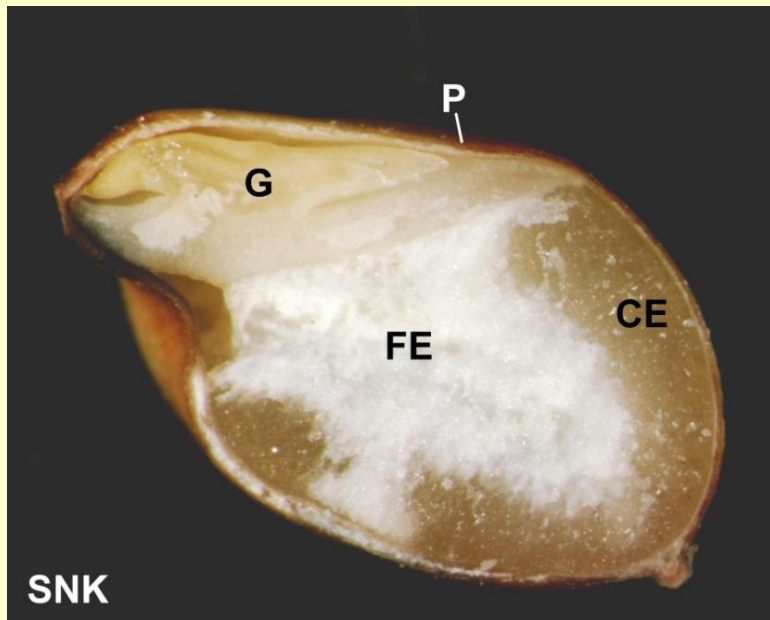

Cross section of the sorghum kernel

P = Pericarp

FE = Floury endosperm

CE = Corneous endosperm

G = Germ

Purpose of milling is to;

- Separate the starch-rich endosperm (84 %) from the pericarp (6 %) and the germ (10 %)
- Reduce the “clean” endosperm to small particles (meal)
- Critical considerations – efficiency (economics) of milling technology and meal quality

Two basic approaches to cereal grain milling

- /// Break open kernel, then scrape endosperm from bran
 - /// Mainly used for wheat milling (roller milling)
 - /// Multiple grinding and separation steps (sifting, aspiration and gravity separation)

- /// Pericarp (bran) and germ are first removed by degerming or decortication, then endosperm is reduced to grits or flour
 - /// Typically used for maize
 - /// Conventional Beall-type degerminator cause breakage of sorghum endosperm; bran contamination (integral germ and spherical shape)

- /// Both approaches have been tried for sorghum

Trends in development of milling technologies



- /// Perten 1983 - Adaption of wheat roller milling technology for sorghum
 - /// Uneconomical low yields
 - /// Products of inferior quality (bran contamination)

- /// Lately small roller mills (2-3 roller pairs) are gaining popularity
 - /// Optimisation of milling process with respect to roller gap, tempering, and sieving
 - /// Improved yields but bran contamination still high

Roller milling cont.

Comparison of milling performance of abrasive decortication and roller milling using 10 sorghum varieties with different physico-chemical properties

Parameter	Abrasive Decortication	Roller Milling
Meal extraction (%)	75.7a	83.7b
Ash (%)	1.18a	1.29b
Oil (%)	2.46a	2.64b
L	84.6b	82.4a
Cab	10.8a	11.6b
hab	70.5b	68.6a

Other considerations;

- Roller mill – narrow particle size distribution; wide for hammer mill
- Roller mill has significantly higher meal output (about 195% higher than abrasive and hammer milling system)
- Roller mill has high energy efficiency (32 kg meal/1kwh), while abrasive hammer mill produced 12.9 kg meal /1kwh

Difficulties with separation of bran

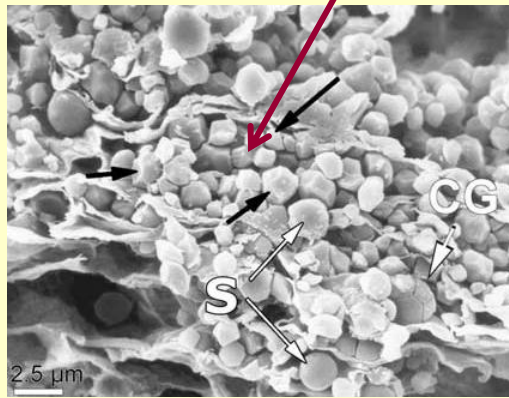

Source: Earp et al (2004)

- /// Starch granules in mesocarp makes pericarp very friable
- /// Forms small bran flakes which are difficult to separate from meal
- /// Bran layer should be toughened to separate as large flakes

- /// Focus on tempering
 - /// Best tempering moisture content
 - /// Treatment temperature
 - /// time

Other technologies considered

- /// German Schule
- /// Swiss Decomatic
- /// Danish United Milling System
- /// Prairie Research Laboratory (PRL) Dehuller
- /// PeriTec system

PRL Dehuller and hammer mill

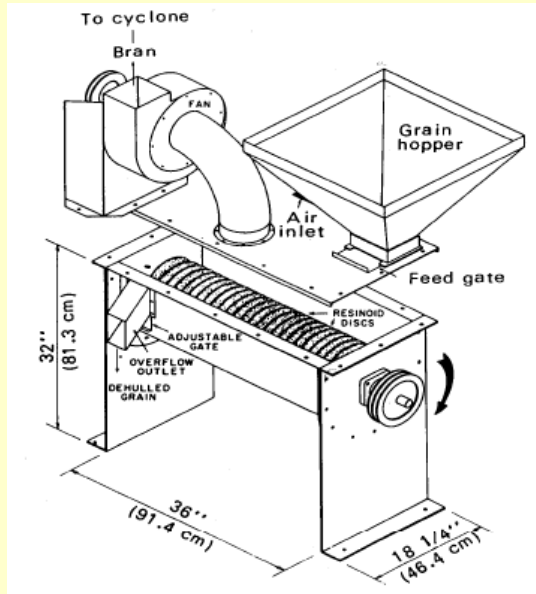

- Canadian PRL dehuller was adapted for local conditions in West, Eastern and Southern Africa, and India
- Dry grain is decorticated by abrasive carborundum disks revolving at high speed in a barrel (fine bran removed by aspiration)
- Milling package (dehuller & hammer mill) was technically and economically viable
- Gave rise to sorghum industry in the region (service milling for villagers)
- Adequate technical support by RIIC contributed to industry success in Botswana



Improvements in production capacities

- Increasing demand for sorghum meal require higher production capacities
- Attempts to build larger dehullers compromised milling efficiency and meal quality
- Commercial mills now install normal PRL dehullers in series and/or in parallel
- 4-5 dehullers feed one hammer mill
- Typical capacities are 2 to 2.5 tons per hr



Production capacities

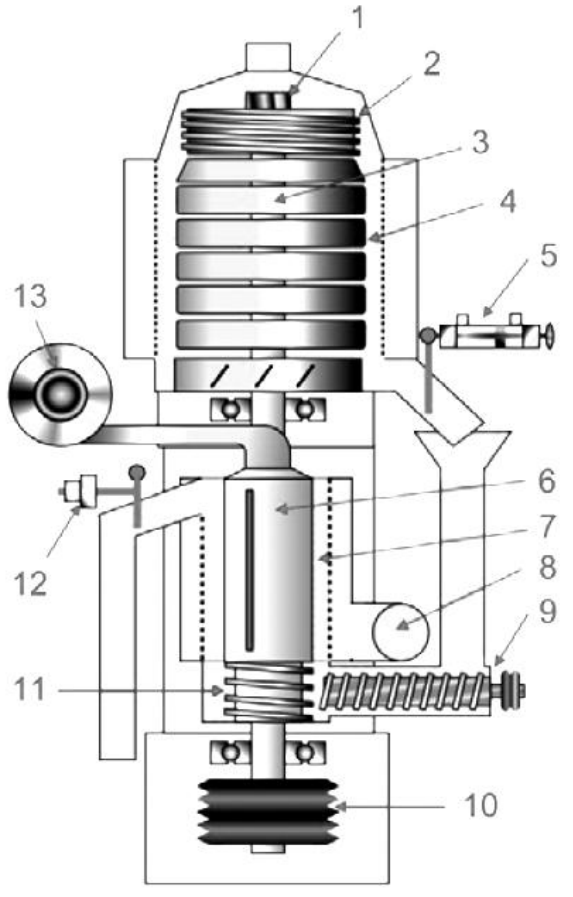

PeriTec system; Used with Satake Corporation's permission

- Some mills now using PeriTec decorticator – Vertical Debranner VCW(Satake Corporation)
- Debrans by abrasion using revolving carborundum wheels and hexagonal slotted screen (stage 1) and friction (stage 2)
- Bran is removed by blowing air through the system from bottom to top outlet
- Requires conditioning of grain with 1-3% moisture (by weight) for 3-5 min before debranning – permits gradual stripping of pericarp layers
- Offers controlled rate of bran removal, uniformly debranned grains and improved power efficiency
- High input capacities – 2 to 10 tons

Grain cleaning

- /// Millers now installing grain cleaning equipment (sieving, aspiration and metal removal)
- /// Necessary for high production capacities



Selection of varieties

- /// Meal quality varies with sorghum varieties used
- /// Millers aim to meet consumer demands
- /// Blending of different varieties commonly practiced
- /// Typically hard to intermediate endosperm texture preferred
- /// Light coloured meals with medium course texture preferred in Botswana
- /// Taste is also important



Conclusions

- /// Abrasive decortication is still the only appropriate technology for decorticating sorghum to meet consumer preferences
- /// Roller milling has potential as an alternative sorghum milling process but still requires optimisation of the tempering process



THANK YOU!